



VAMISOUND

THE SOUND
IS YOURS

V-414

BUILDING
INSTRUCTIONS



VAMISOUND V-414 BUILDING INSTRUCTIONS

WE SOUND BETTER

Dear **DIY** friend,

first of all thank you for your support and choice of the VAMISOUND product. We wish you a happy DIY and the joy of a new microphone in your arsenal!!

Jan and Milan

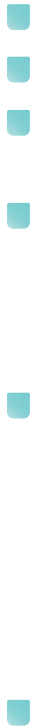



VAMISOUND V-414 BUILDING INSTRUCTIONS

WE SOUND BETTER

Before you start building your new microphone please carefully read this building instructions.

Attention: V-414 is not DIY beginners project. This is due to the fact that the circuit is very complex and boards designed with very limited space in the microphone body in mind. Good soldering experience and soldering stations with very fine soldering tip is required for successful completion of the construction. If you do not have this, please delegate the construction to a more experienced technician with proper equipment. We are not responsible for malfunctioning construction or injuries associated with improper assembly of our kits.

Document info	
Document name	V-414 building instructions
Document revision	1.1
PCB revision	1.1
Date	September 2024
Project difficulty	★★★★
Complexity of soldering	★★★★☆
Risk of electric shock	★☆☆☆☆
Changes and notes	15.09.2024 capsule holder info added

VAMISOUND V-414 set includes main parts board, transformer board, switch board, three switches and four teflon pins.

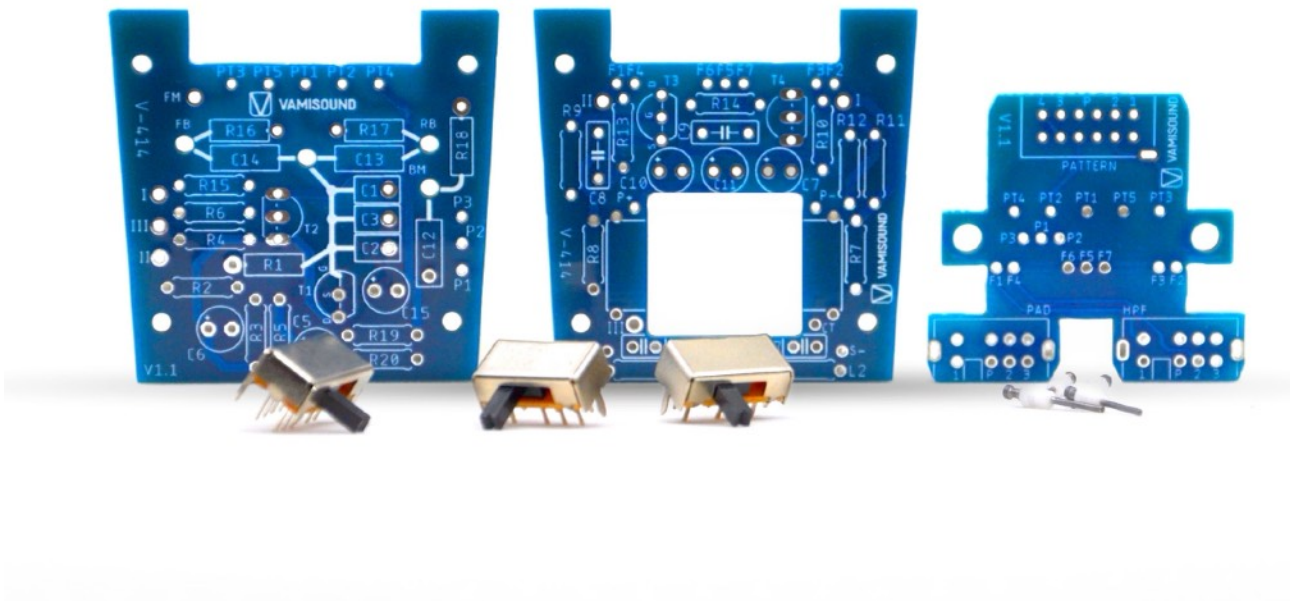

Start fitting the transformer board with resistors and two inductors.

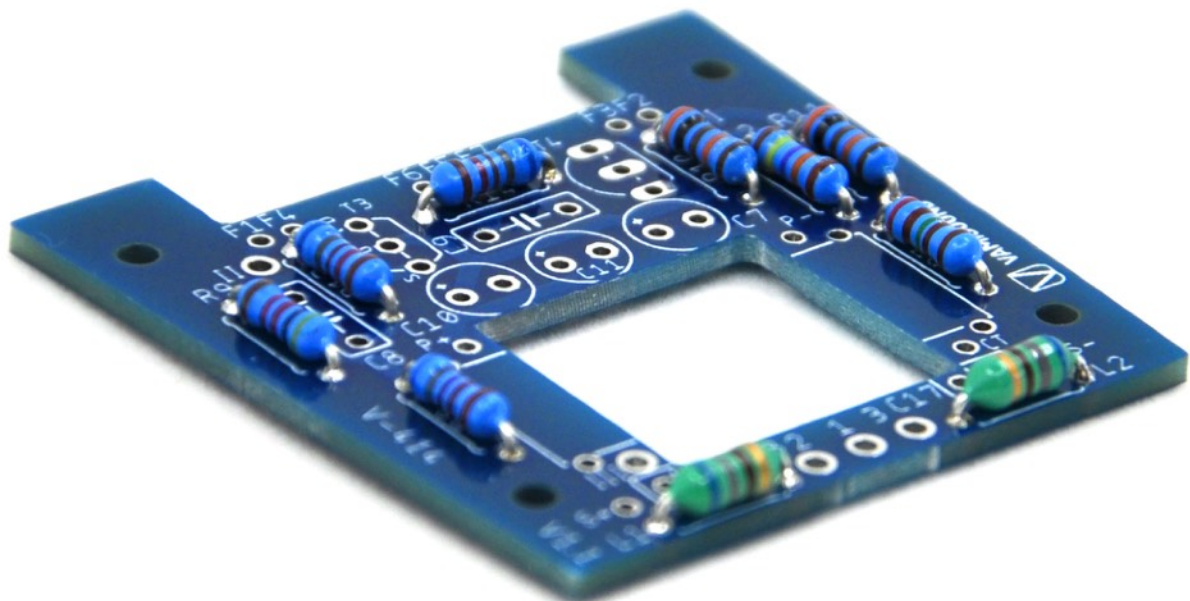

Continue with soldering two red film capacitors, two blue ceramic capacitors, three electrolytic capacitors and two transistors.

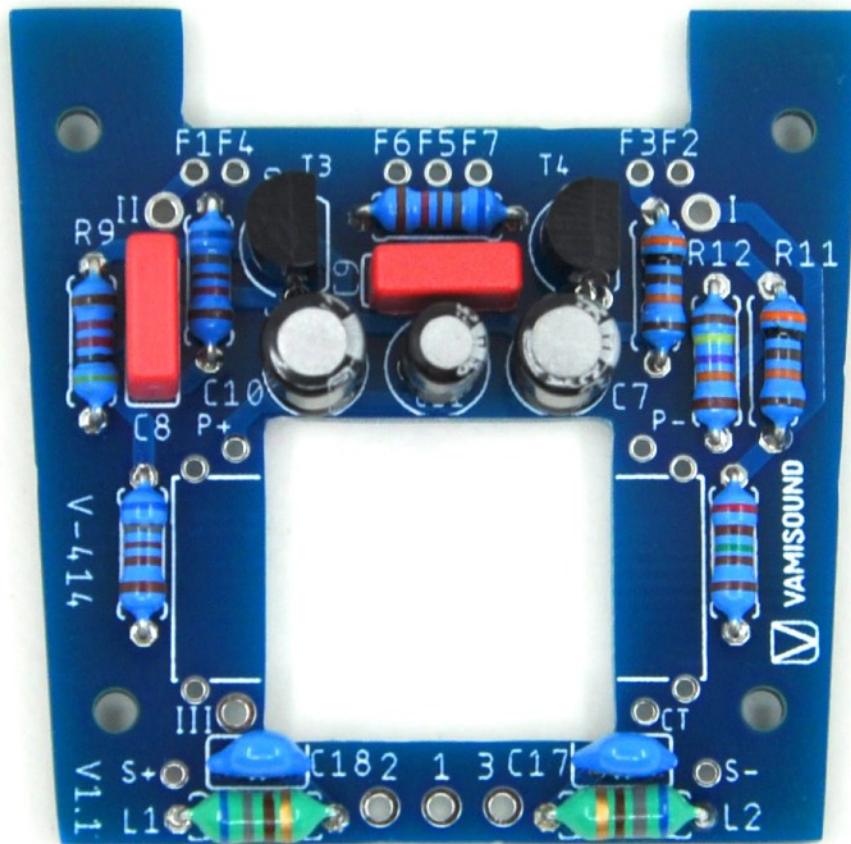

Next up is the main parts board with point to point HiZ section. Soldering the HiZ section might seem a bit more challenging but with a little patience you can do it.

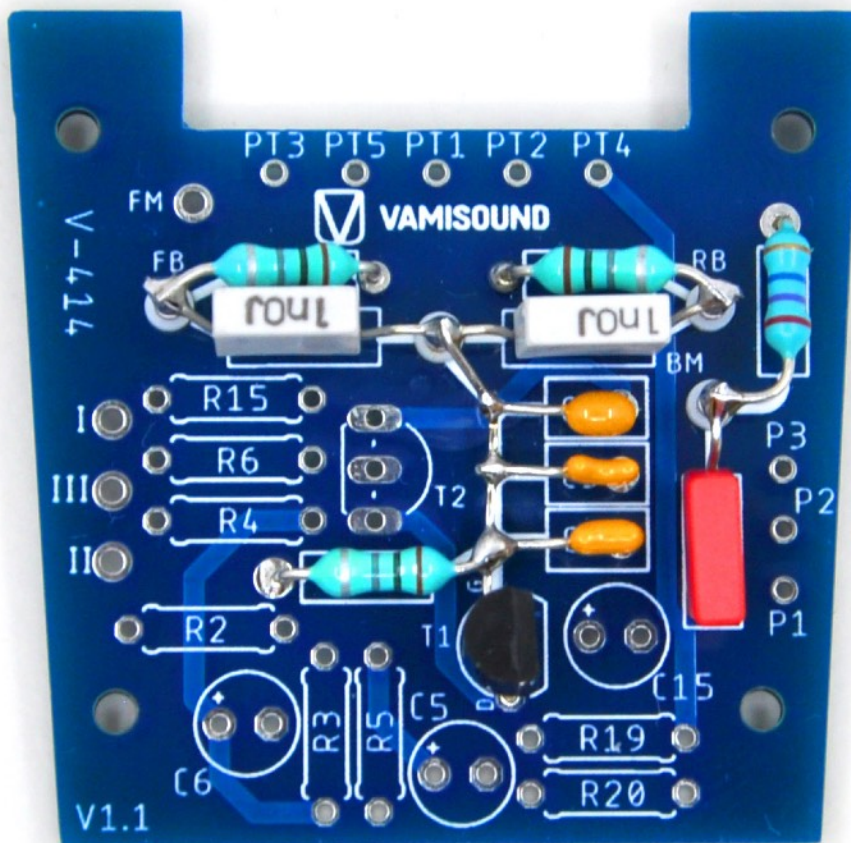

As you can see in the picture, on the gate leg of the fet transistor there are three ceramic capacitors, one resistor and also two film capacitors soldered „in the air“. There are also four teflon pins.

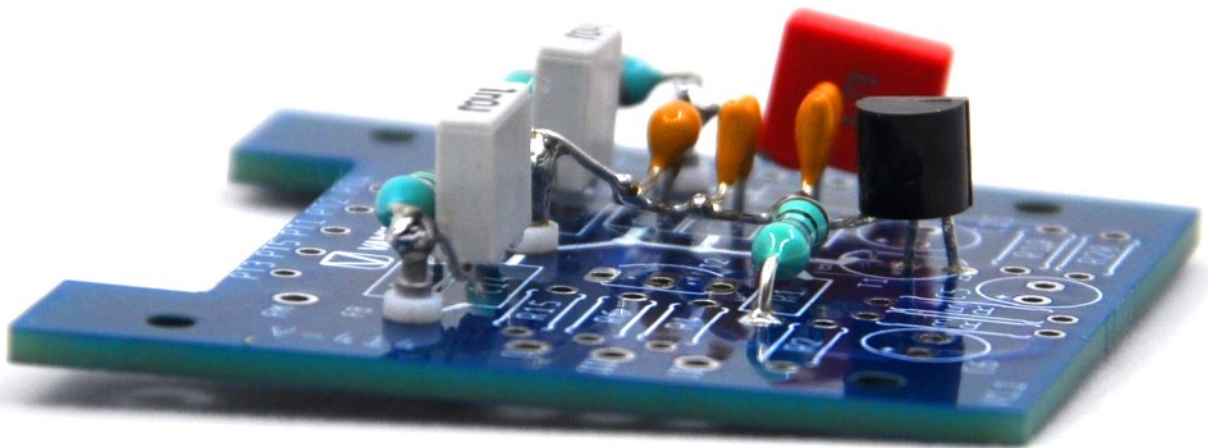
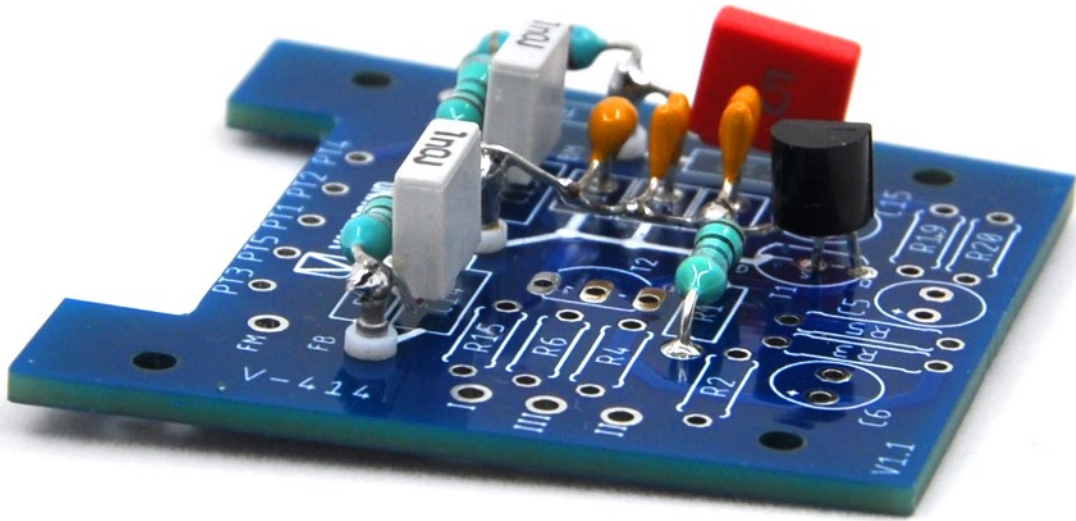

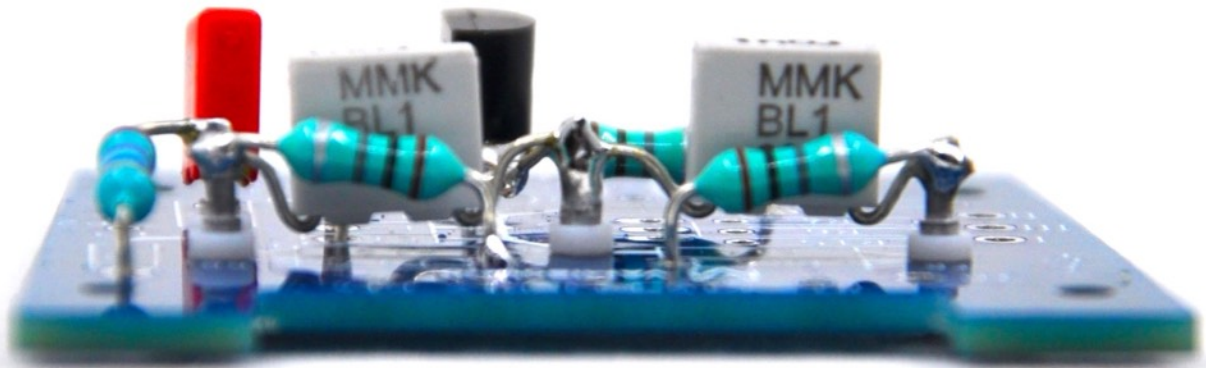

After completing the HiZ section clean the entire area with isopropyl alcohol. Use cotton cleaning sticks. Make sure there is no flux residue or other contaminants on the joints.

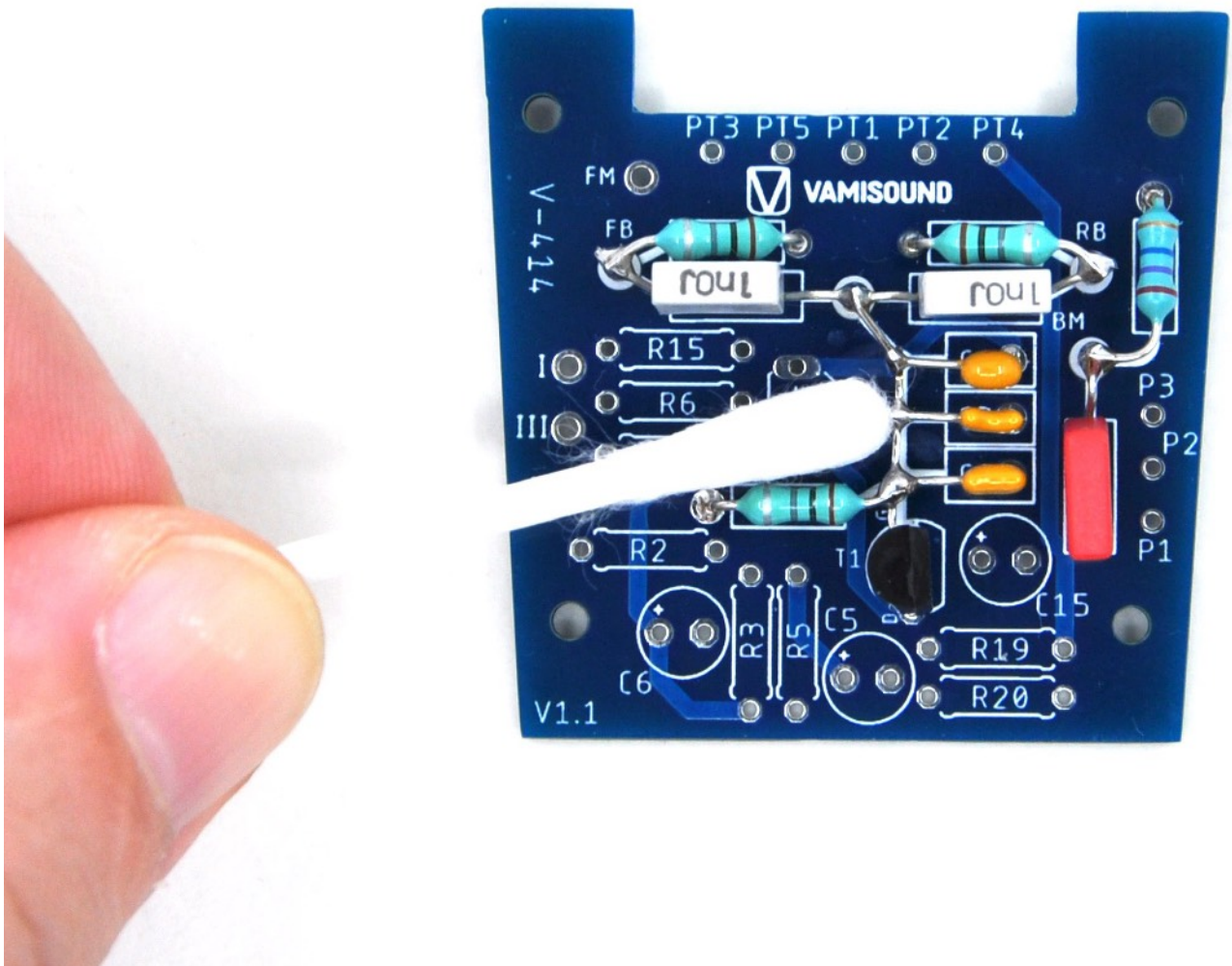

After cleaning, fit the rest of the board with resistors, capacitors and last transistor.

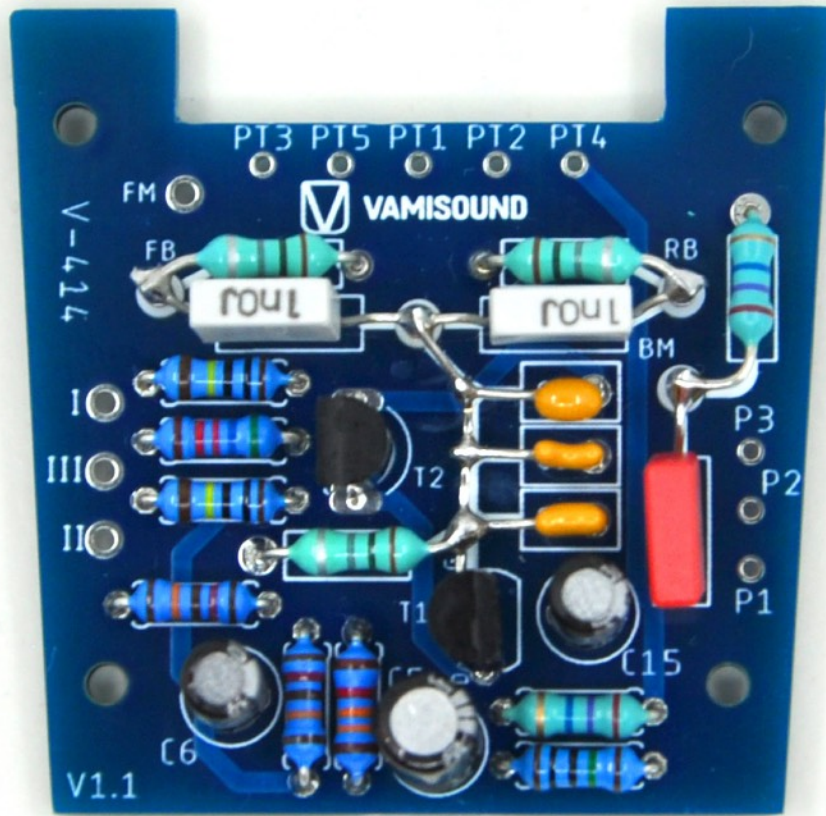

Next in line is switch board. Solder the three switches into place. On the 4 position pattern switch use pliers to snap one pin protruding from the metal body to fit the switch board. Try to insert this switch into the pads on the board before soldering and it will be immediately clear.

Use the remaining legs of the resistors/capacitors and solder them on the switch pcb as follows:

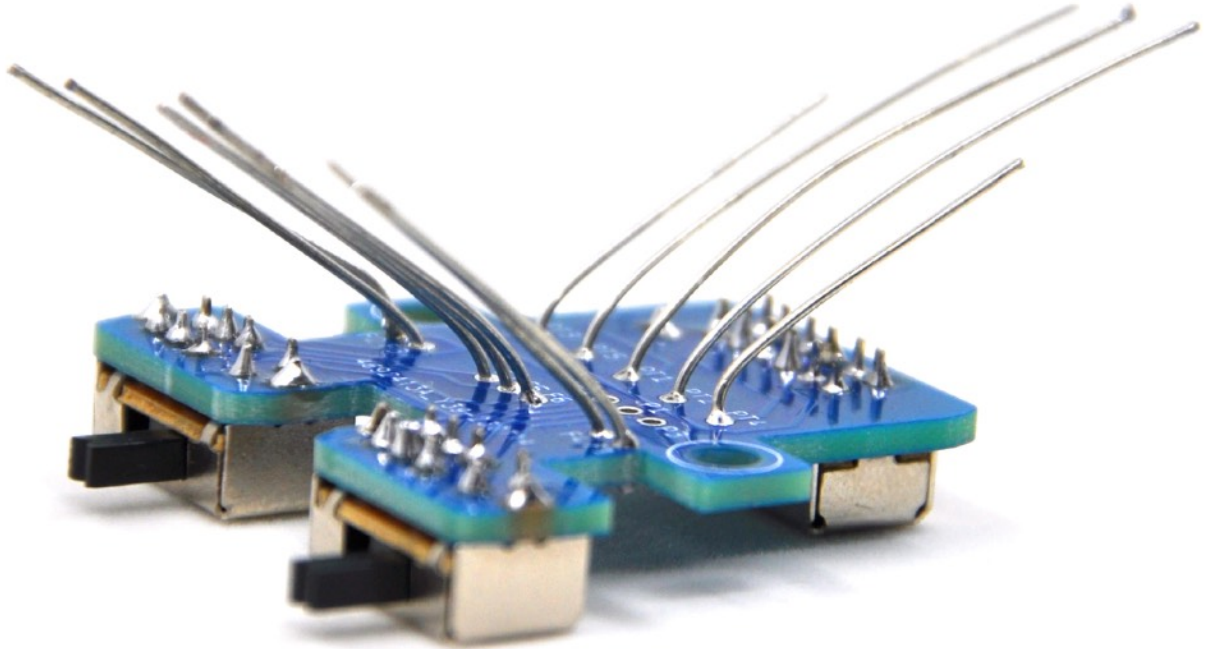

Make sure you solder the resistor legs to the correct side of the board.

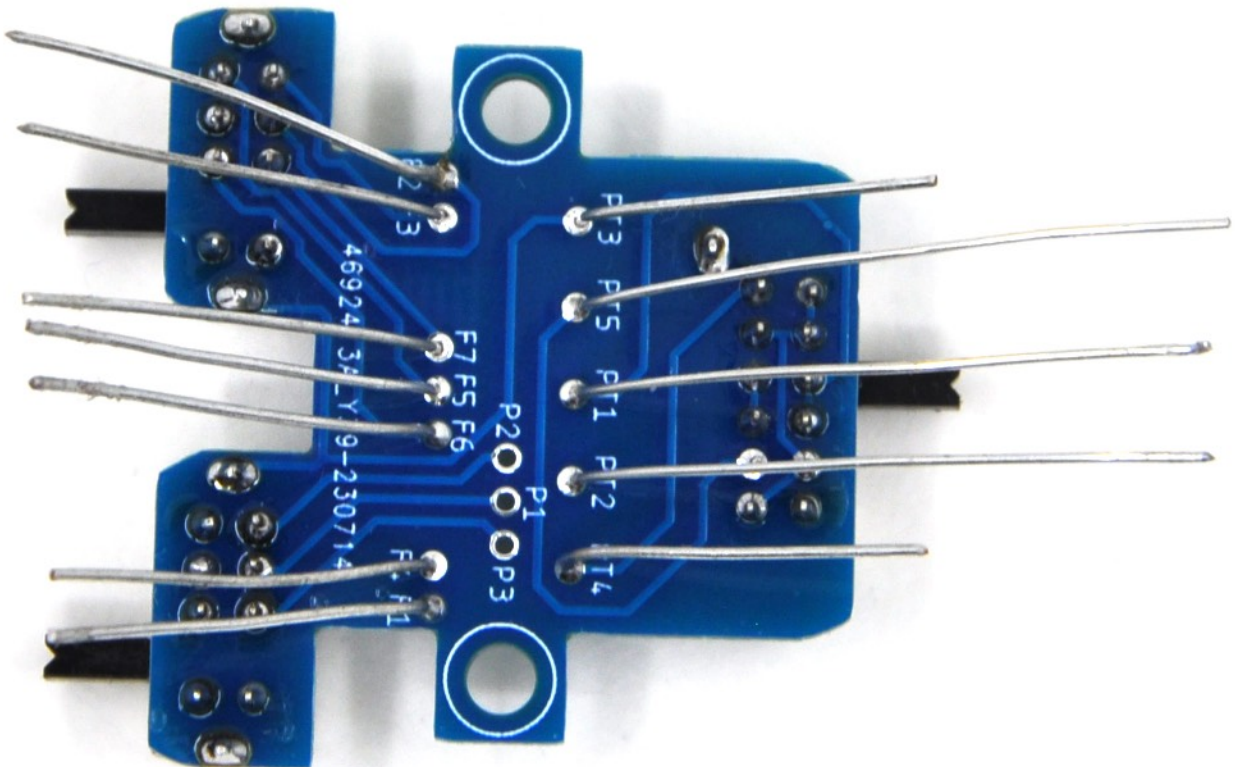

Carefully but thoroughly clean all plates with isopropyl alcohol. Pay particular attention to the switches to prevent isopropyl alcohol from entering them.

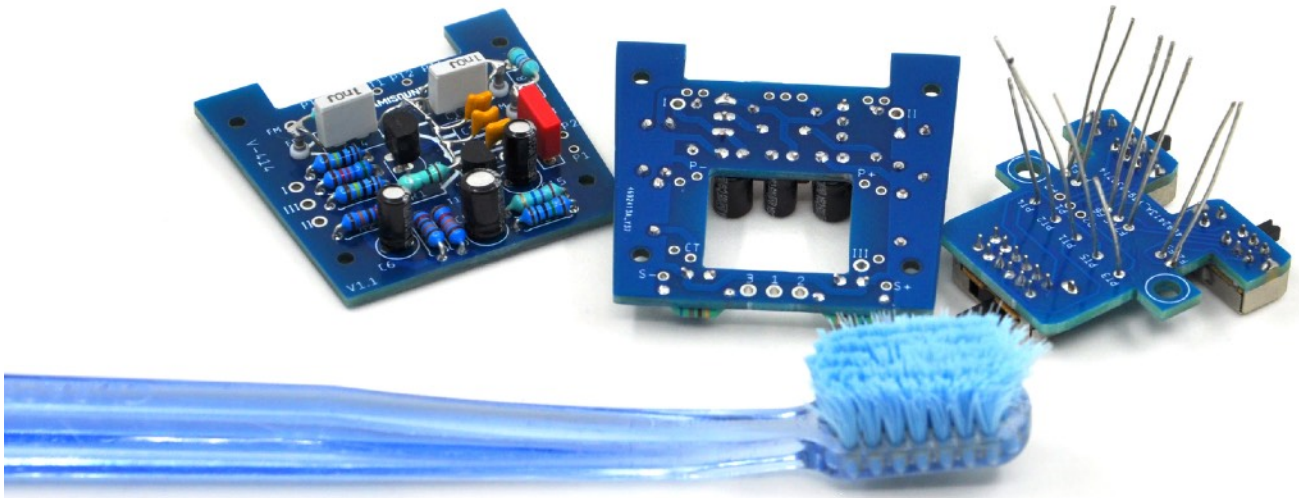

Everything is now thoroughly cleaned so we can move on to more pleasant things.

Installing the famous Moby's transformer is always a fantastic experience. Insert the transformer into the cutout of the board and carefully pull its cables through to the other side of the board. Do this carefully as the cables are very delicate and can easily break.

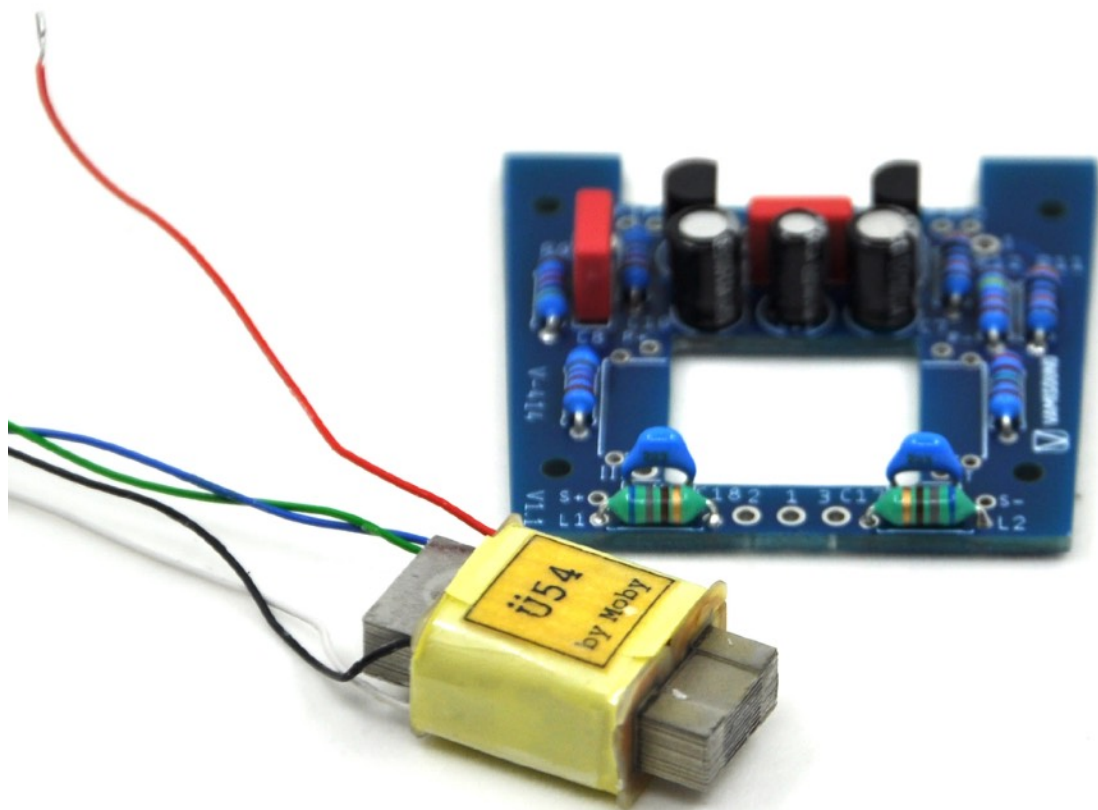

Again, use the remaining resistors/capacitors legs to attach the transformer to the board. Make sure you tighten these well to keep the transformer from slipping.

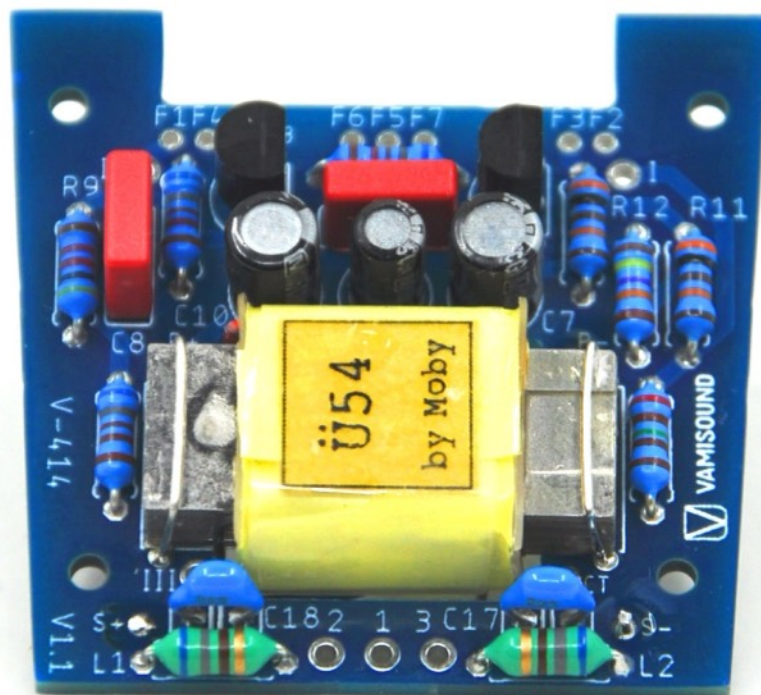

Solder the transformer cables to their pads on the board. P+ = primary winding start (blue cable on Ü54 transformer), P- = primary winding end (black cable), S+ = secondary winding start (red cable), S- = secondary winding end (white cable) and CT = secondary center tap (green wire). When the microphone is finished, check the microphone phase and swap the two cables if necessary.

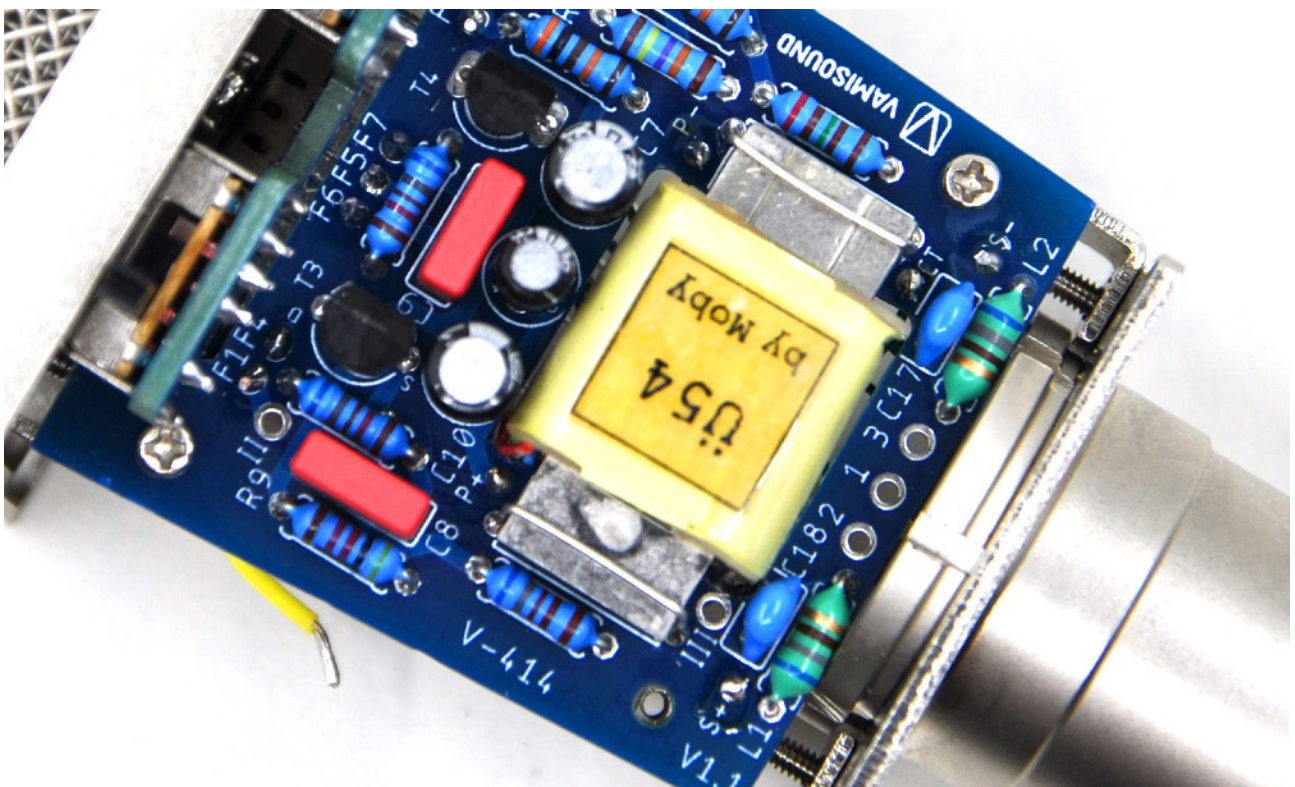

Do the following step very carefully because you will be installing the capsule respectively its stand on a metal plate. Protect the capsule with an empty parts bag. Before doing so unscrew this plate from the 414 body chassis of course.

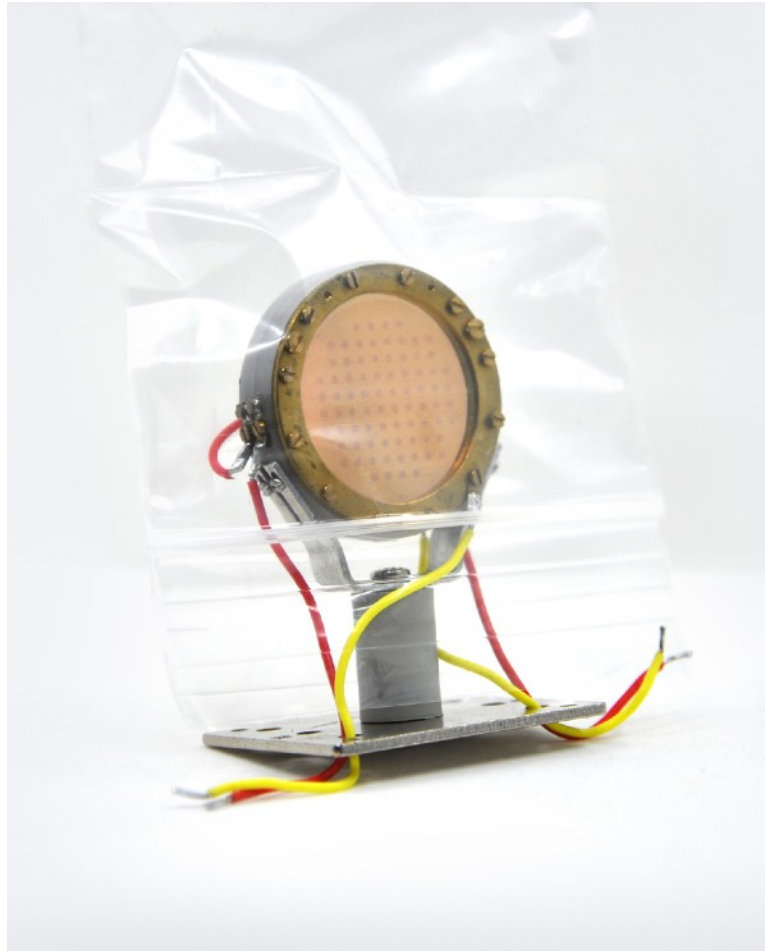

Thread the cables leading from the capsule through the holes in the plate to facilitate later work.

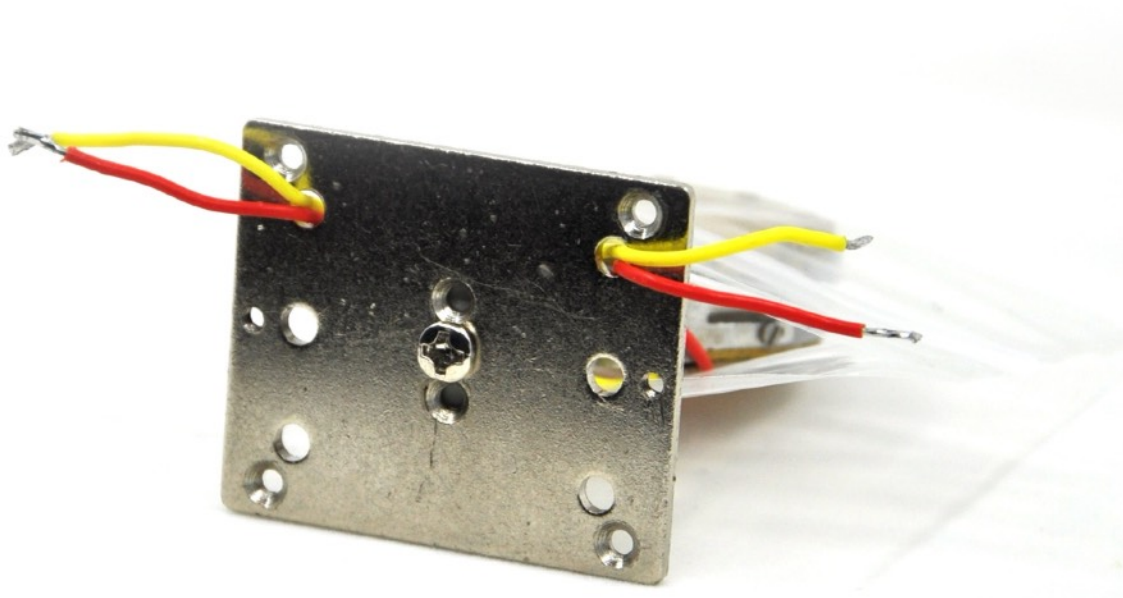

Install two 10mm long M3 screws into the two holes in the switch board. Secure them with a nut.

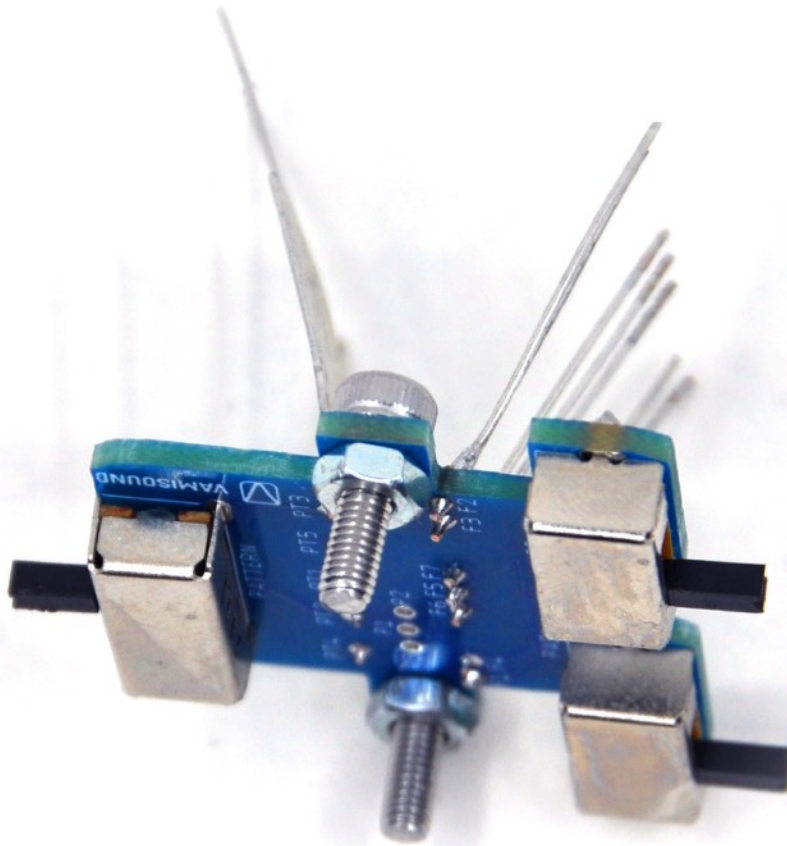

Insert the entire switch board into the metal plate that holds the capsule. Be careful not to damage the capsule.

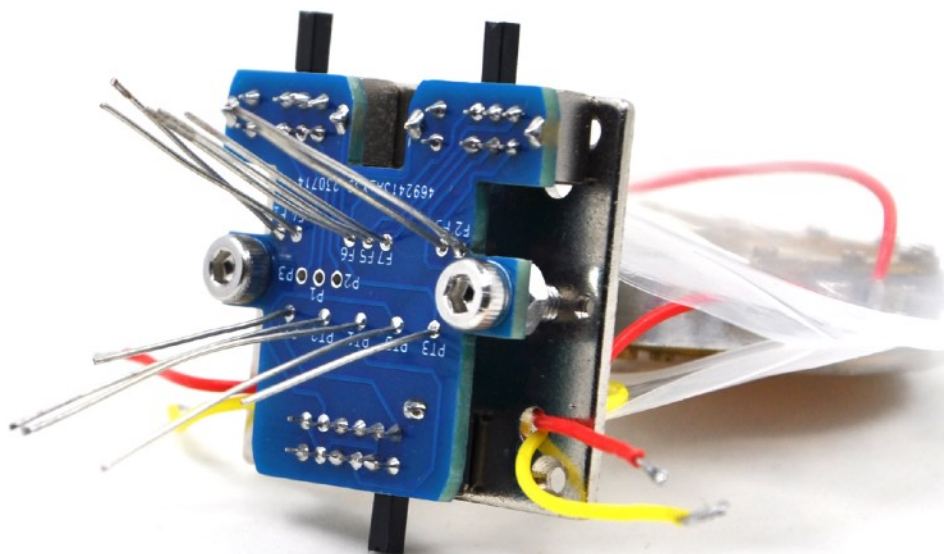

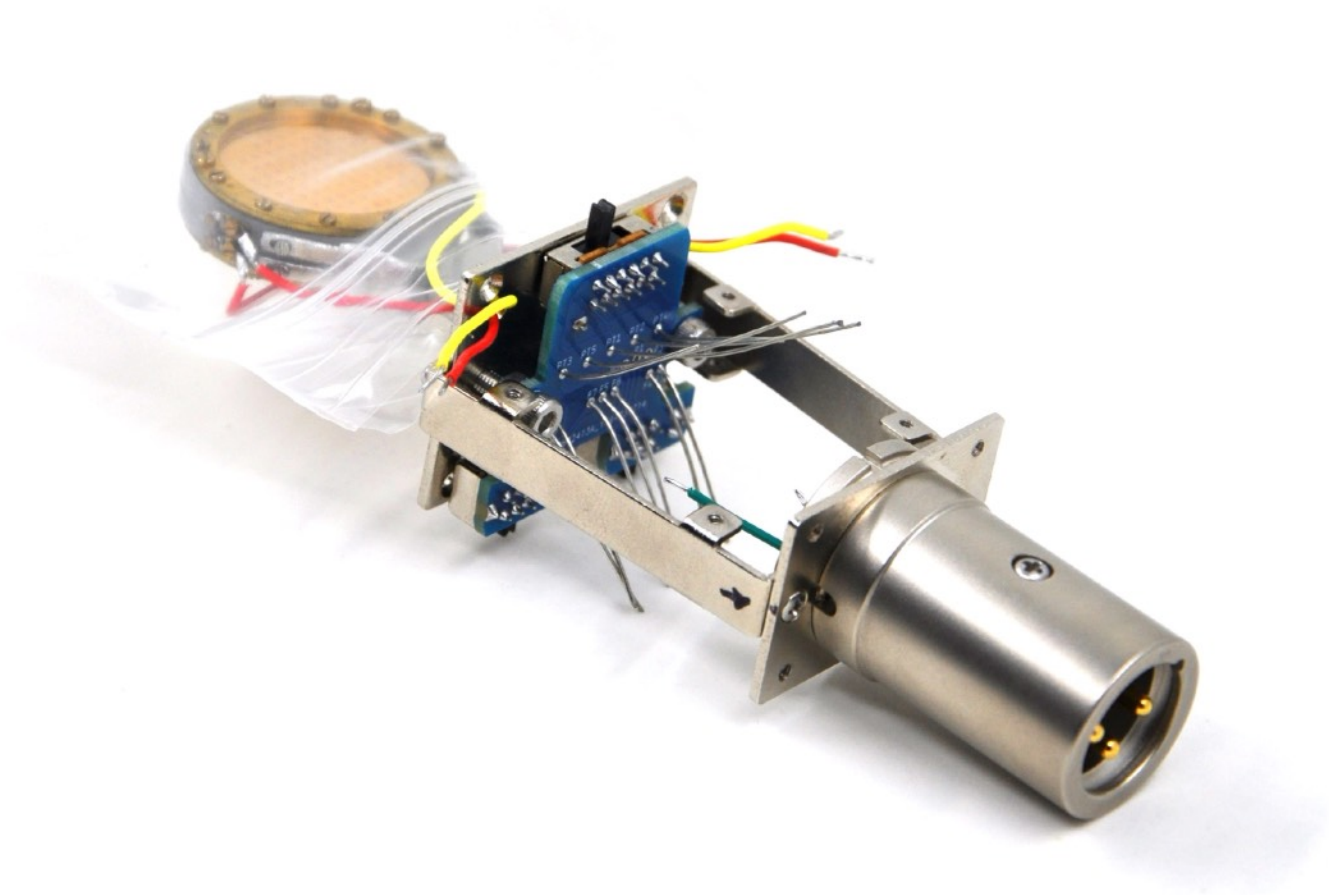

It is not necessary to screw the two M3 screws to the metal plate from above. The switch plate will hold firmly enough when all three plates are assembled together.

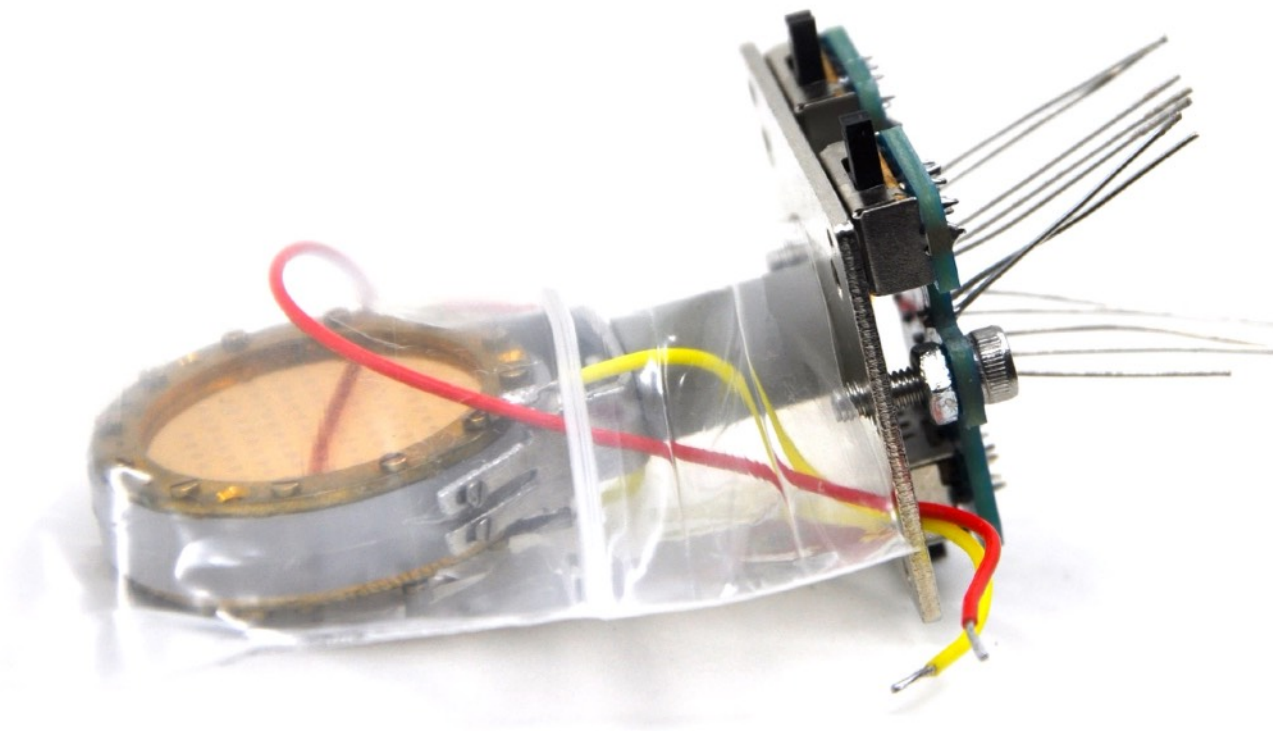

In the next step mount the transformer board on the 7 resistor legs protruding from the switch board. It may be a good idea to unscrew the bottom of the 414 body for easier installation. Don't solder the two boards together yet.

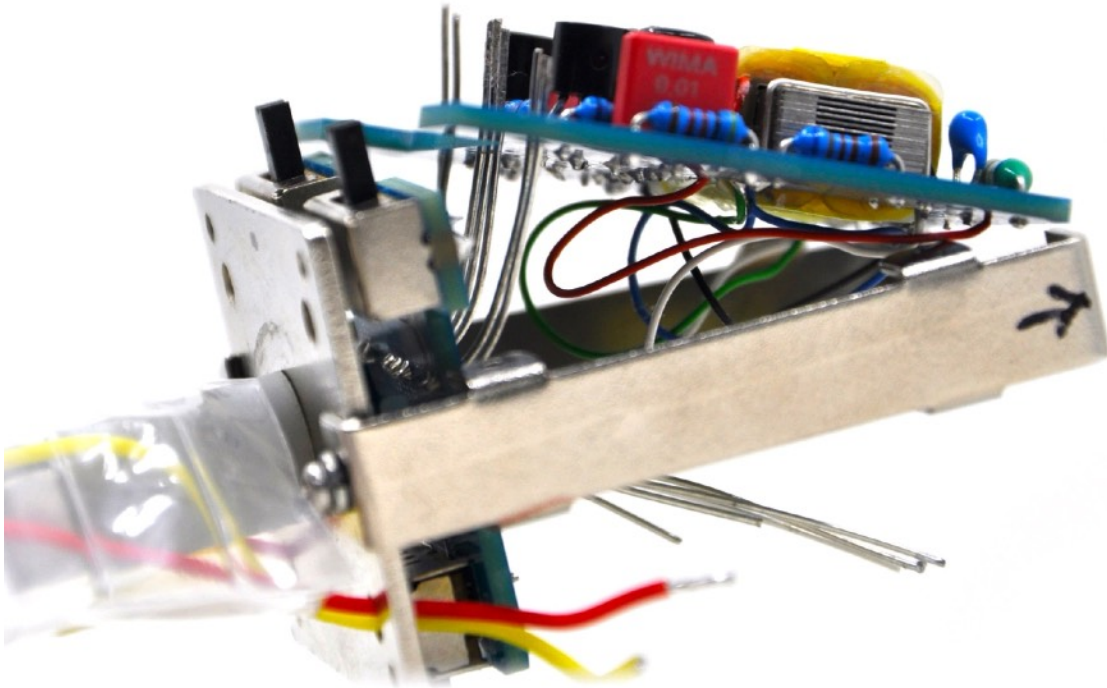

Install the head basket. Attach it to the chassis of body with only two screws on the sides of the 4 position pattern switch. Do not use the remaining two screws on the opposite side as there is not enough space under the PAD and HPF switch. This is one of the compromises we were forced to make during the design process. Of course it's DIY so maybe another solution is possible.

From the opposite side of the board check the connection and make sure there is no unwanted connection to ground or short between the resistor legs that were used to connect the boards.

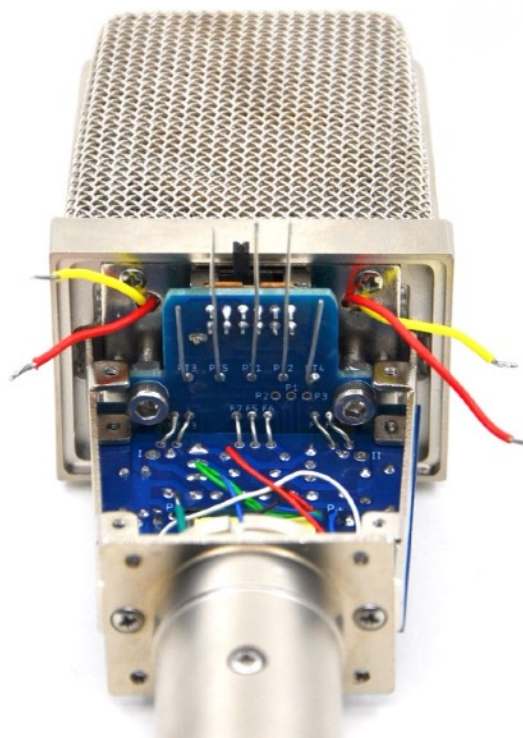

Focus on the switches and their levers because already at this stage you can adjust the height of the switch board from head basket. Also you can now put the metal microphone body on the chassis and check that the switches fit perfectly in their holes. After setting the height of the switch board you can finally solder the two boards (switch board and transformer board) together.

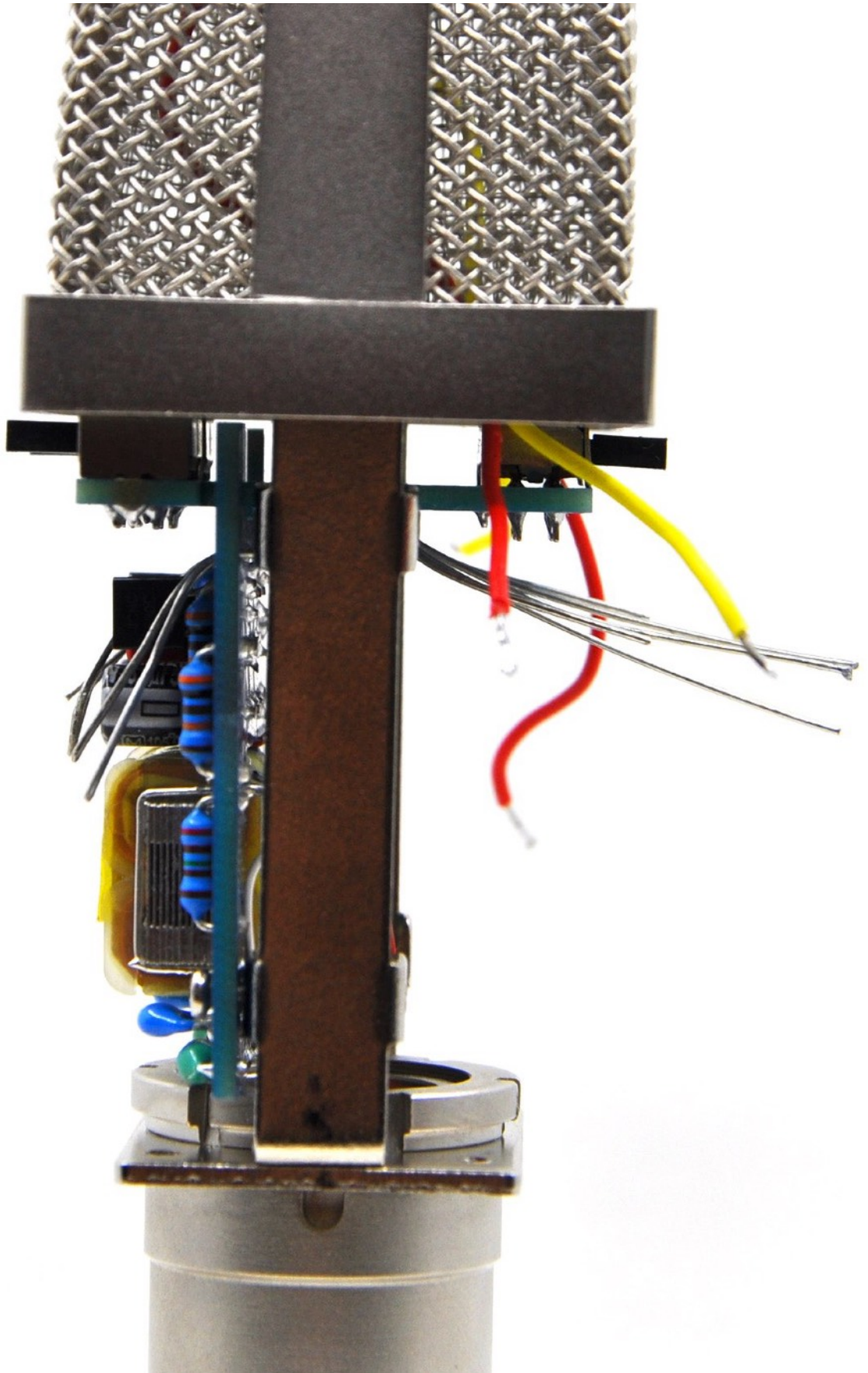

Solder the wires to the XLR insert pins. The length of the cables is approximately 5cm. Connect pin 1 to the ground eyelet on the insert. The resistor leg will serve you for this again.



Solder the three cables to the board. In the picture you can also notice the connection of the transformer cables.

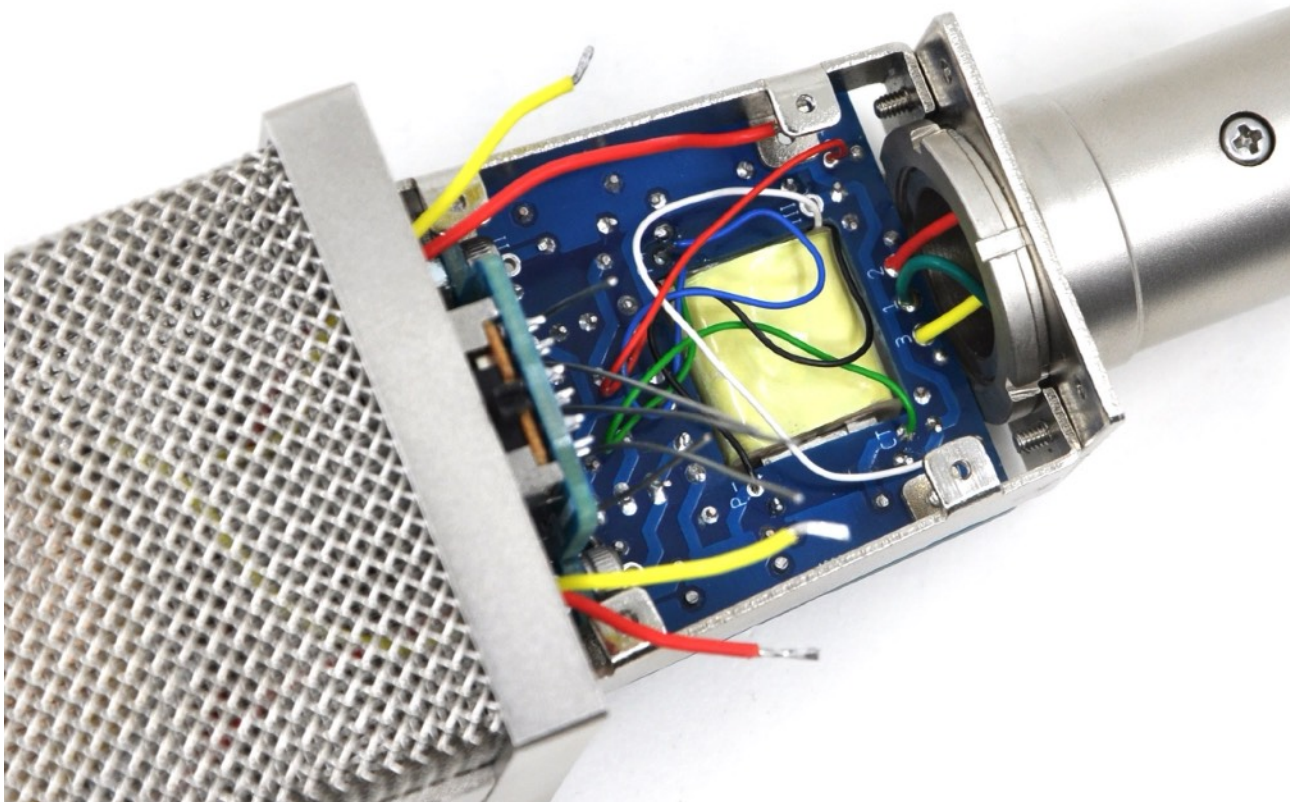

In the next step solder three cables to the board that will later connect the transformer board to the main parts board. Insert the cables from the inside into the pads marked I, II and III.

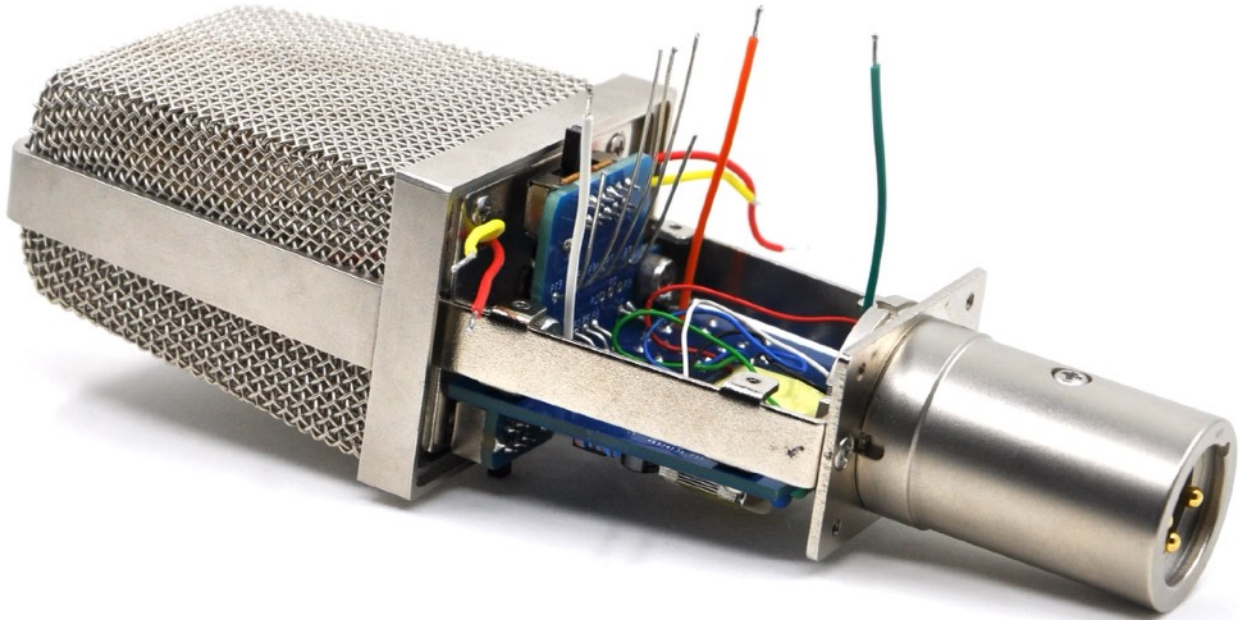

Solder another three cables to the switch board (P1, P2, P3 pads) which will later connect the switch board to the main parts board.

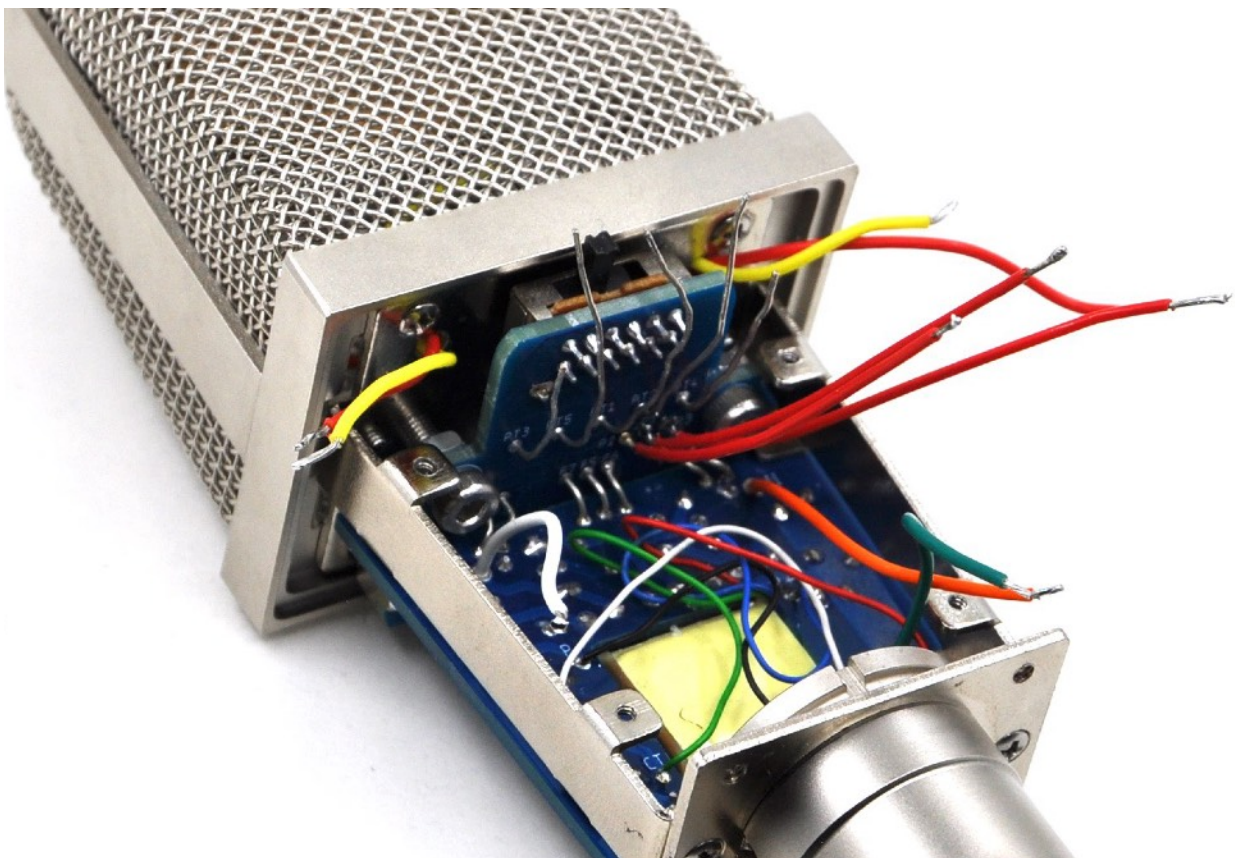

It's time to connect the switch board to the main parts board. Connect the cables leading from the switch board to pads P1, P2 and P3 which are on the main parts board too. Also solder the three remaining cables leading from transformer board to pads I, II and III on the main parts board.

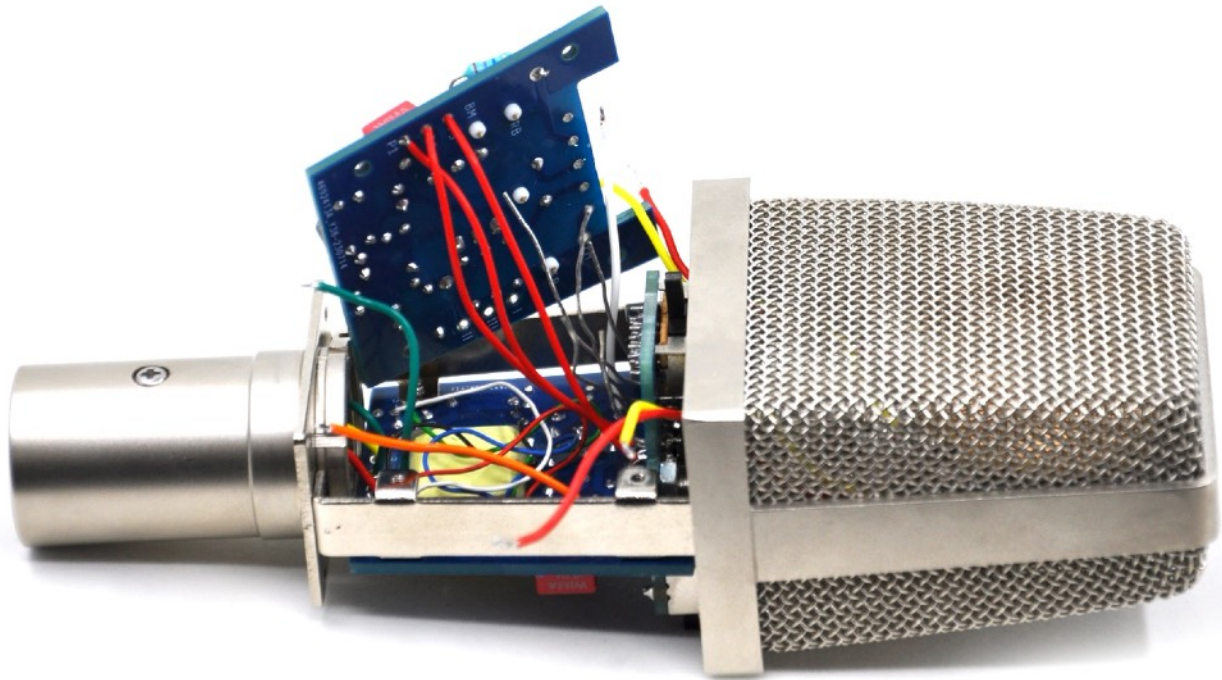

Press the main parts board carefully to the chassis and fasten the board with screws. Make sure no cables are pinched under the board. Make sure the five resistor legs do not make unwanted connections or short circuits inside.

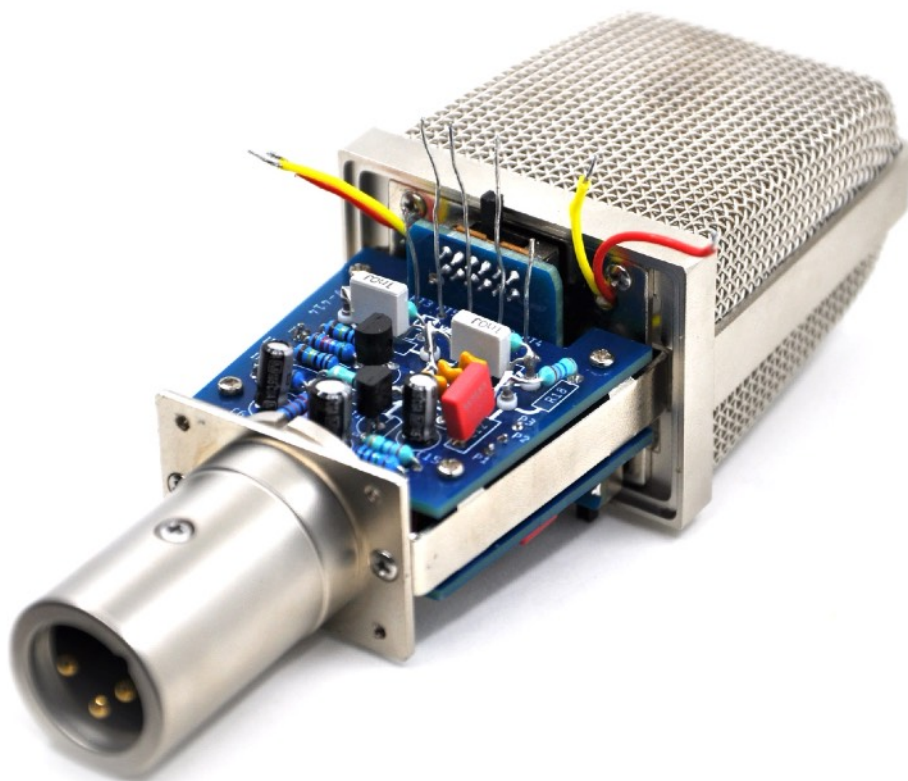

After soldering the five connection points we have all three boards firmly connected to each other and the circuit is almost complete.

All that's left is to connect the four cables from the capsule. Solder the cable from the front diaphragm of the C12 capsule to the „FM“ pad on main parts board. Front backplate to the teflon pin which is marked „FB“. Connect the cable from the rear diaphragm to the teflon pin marked „BM“. And finally the cable from the rear back plate to the teflon pin „RB“.

It is always a good idea to carefully clean these HiZ connections with isopropyl alcohol to remove any soldering debris.



Well, congratulations, because right now your new microphone is practically complete!!!! Connect the microphone to the preamp, activate phantom power and check everything necessary.



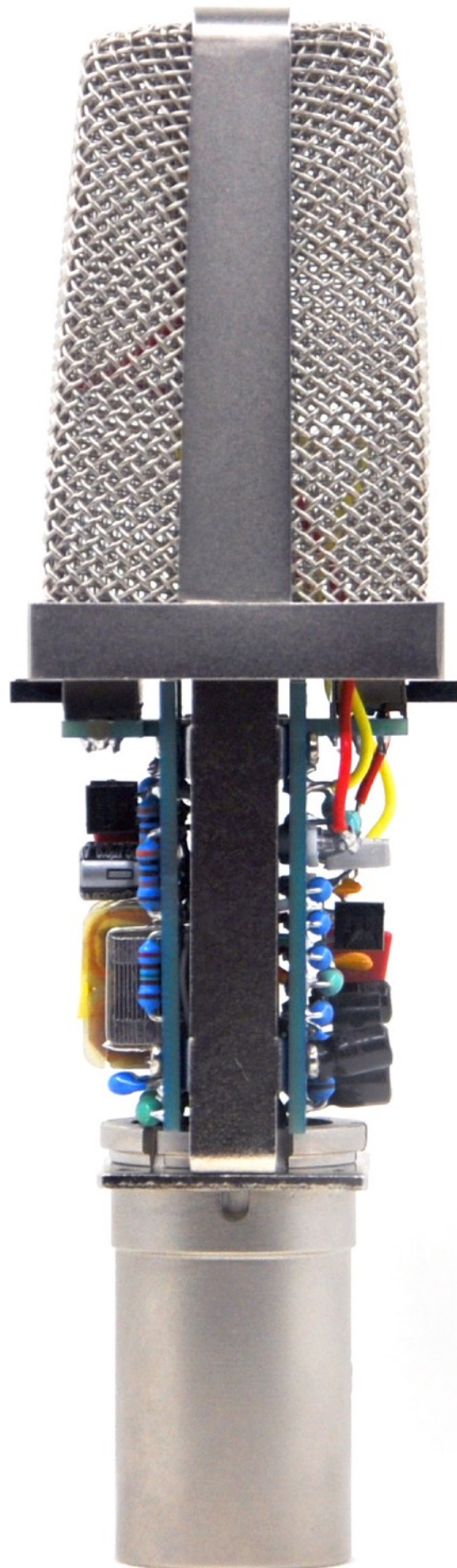

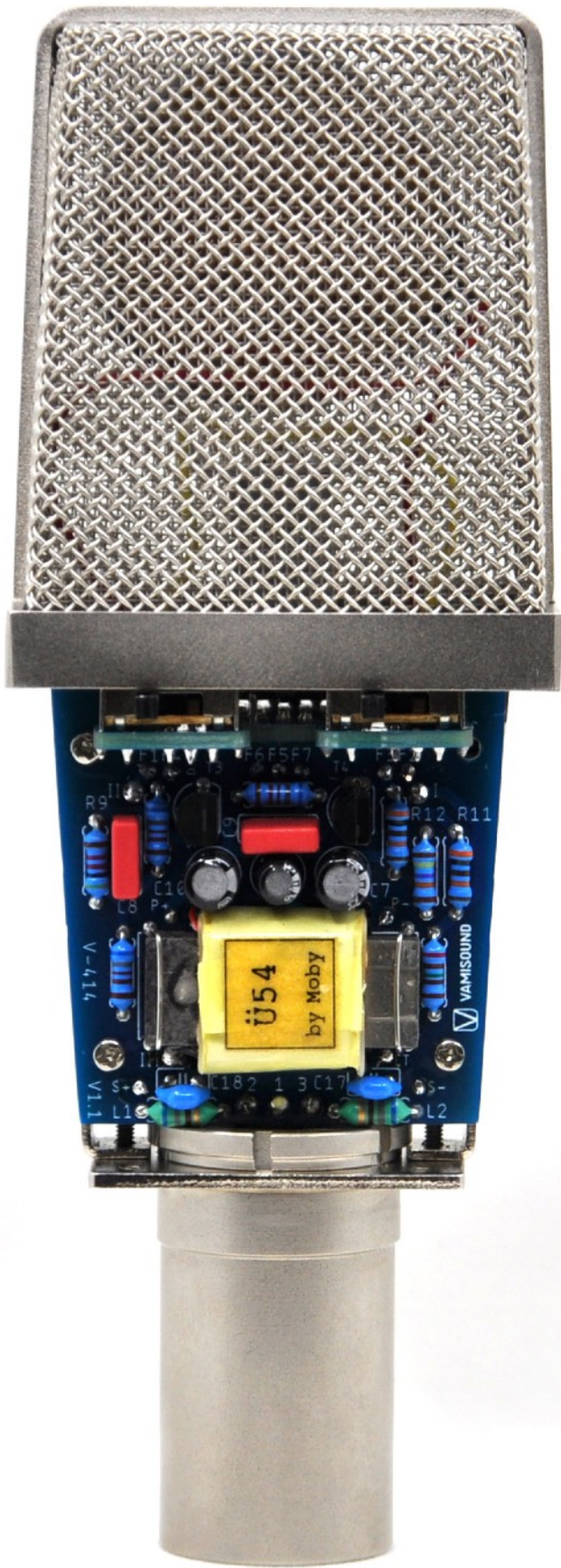





0 -10 -20
dB

0 75 150
— Hz /

WIRING INFO

- 1) Connect transformer board and main parts board via pad I, II and III..... I=>I II=>II III=>III Use three wires for this.
- 2) Connect main parts board to switch board. Use three wires and interconnect pads P1, P2 and P3 on main parts board to pads P1, P2 and P3 on switch board.
- 3) Connect main parts board to switch board in this case via cutted resistors legs. Interconnect pads PT1, PT2, PT3, PT4 and PT5.
- 4) Connect transformer board and switch board via resistors legs. Interconnect pads F1, F2, F3, F4, F5, F6 and F7.
- 5) Join XLR1 pin via wire to pad 1 on main parts board. XLR2 pin to pad 2 and XLR3 pin to pad 3 on main parts board. Joint XLR1 pin via resistor leg to xlr "ground lug" (on connector insert) = its mic body to XLR1 pin (0V) connection.
- 6) C12 capsule wiring: Front membrane to FM, back membrane to BM, front backplate to FB, rear backplate to RB
- 7) Moby´s Ü54 transformer wiring: Primary start cable (blue cable) to P+, primary end cable (black) to P-, secondary start cable (red) to S+, secondary end cable (white) to S-. Secondary center tap cable (green) to CT hole on the transformer board.
- 8) Its always great idea to check phase of DIY microphone against commercial microphone.

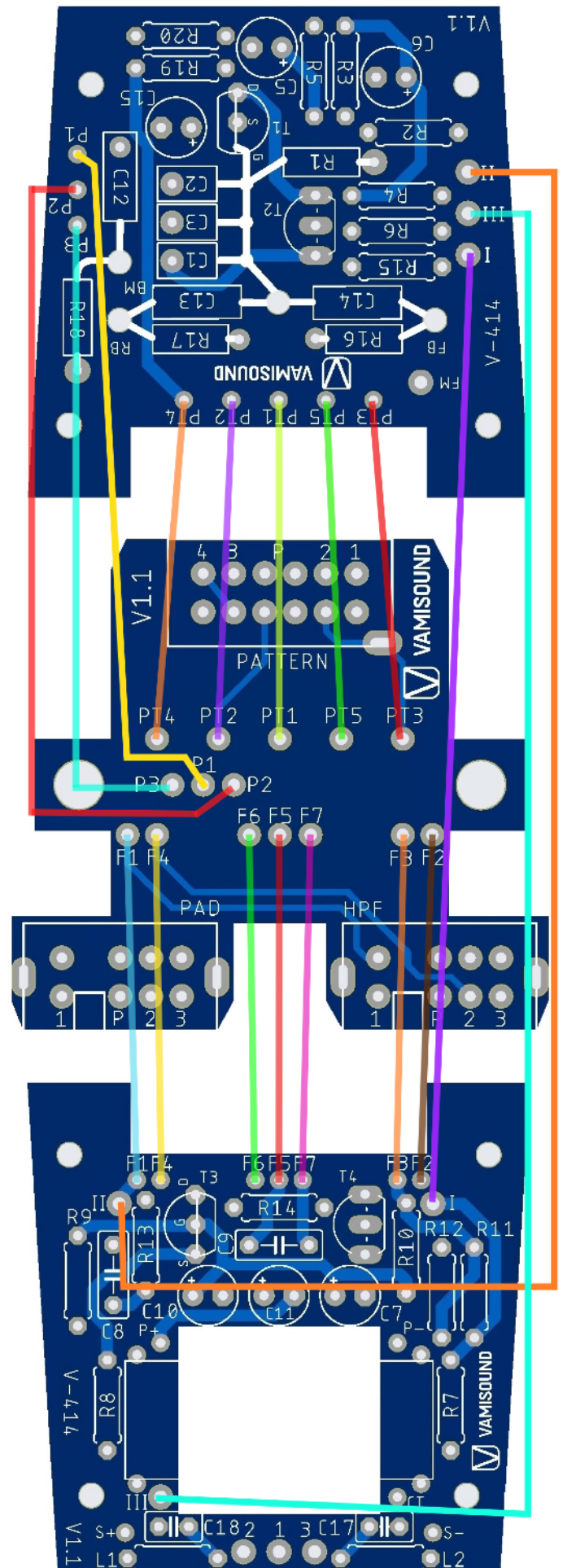

ADDITIONAL INFO

- 1) Do not install two small screws under the HPF and PAD switches. There's no space for their installation because no free space under the switches. Four screws on the bottom side of 414 Chinese mic body and another two screws near the pattern switch will do their job.
- 2) You can carefully drill a small hole for a screw between the HPF and PAD switch and join the capsule metal plate with the head basket. Of course you have to solve how to join the metal plate to the head basket so some mechanical skills and tools are needed.
- 3) Take your time when soldering the switches. You don't want to burn the plastic of the switch lever. Take a break while soldering the individual switch pins.

BILL OF MATERIAL

Part	Value	Tol.	Min. V olt.	Dimmensions	link 1	link 2	notes
Inductors							
L1	680uH				mouser link		
L2	680uH				mouser link		
Resistors							
R1	1G	10 %		6.5x2.5mm	mouser link		
R2	121K	1 %			mouser link		
R3	121K	1 %			mouser link		
R4	1M	1 %			mouser link		
R5	13K3	1 %			mouser link		* FET1 bias setup
R6	56K2	1 %			mouser link		
R7	2K15	1 %			mouser link		
R8	6K81	1 %			mouser link		*FET2 bias setup
R9	40K2	1 %			mouser link		
R10	301K	1 %			mouser link		
R11	301K	1 %			mouser link		
R12	147K	1 %			mouser link		
R13	68K1	1 %			mouser link		
R14	68K1	1 %			mouser link		
R15	1M	1 %			mouser link		
R16	1G	10 %		6.5x2.5mm	mouser link		
R17	1G	10 %		6.5x2.5mm	mouser link		
R18	27M	5 %		6.5x2.5mm	mouser link	farnell link	
R19	27M	5 %		6.5x2.5mm	mouser link	farnell link	
R20	10M	1 %		6.3x2.3mm	mouser link		

